

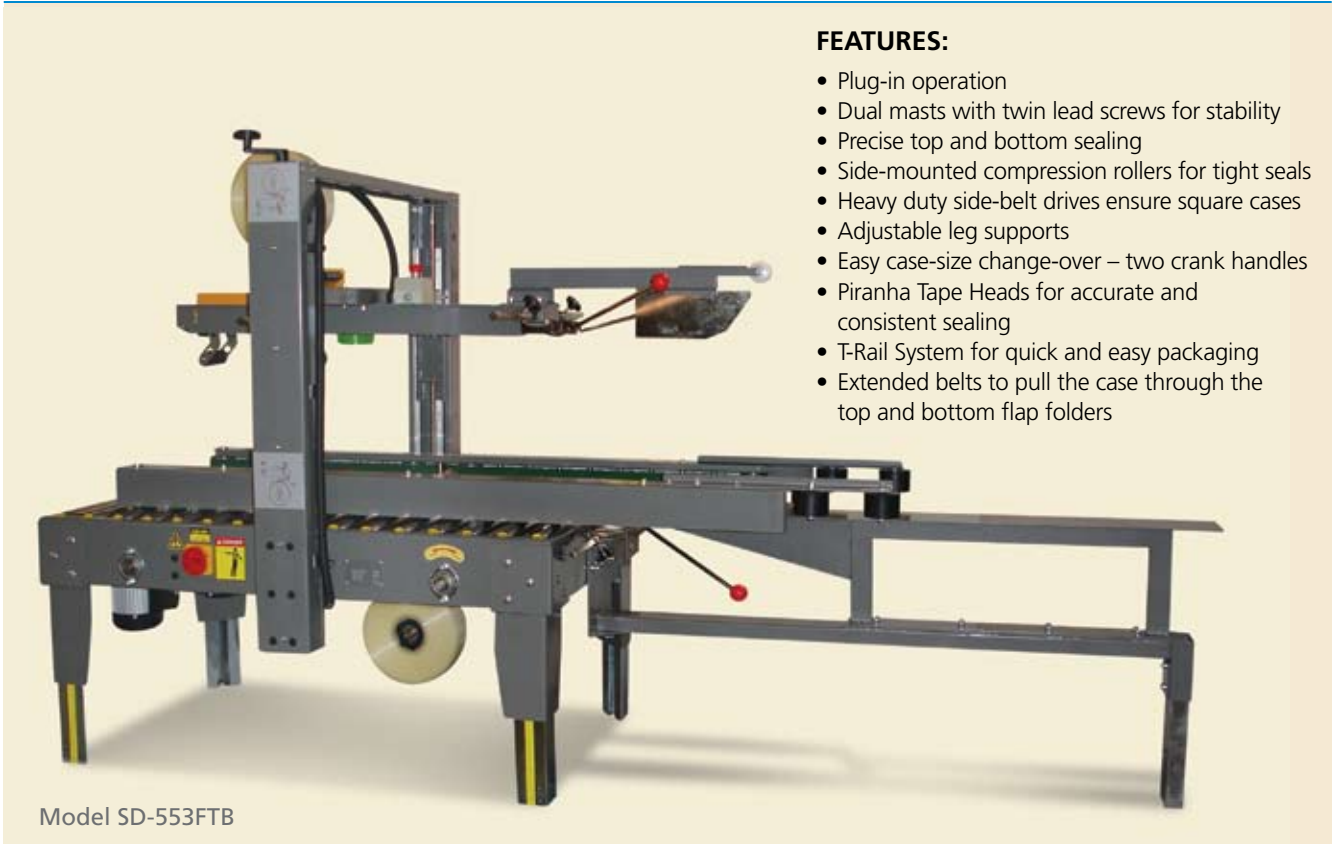

SIDE BELT ADJUSTABLE TOP AND BOTTOM FLAP FOLDING SEALER

Competitive Pricing Without Sacrificing Quality

SIDE BELT ADJUSTABLE TOP AND BOTTOM FLAP FOLDING SEALER



FEATURES:

- Plug-in operation
- Dual masts with twin lead screws for stability
- Precise top and bottom sealing
- Side-mounted compression rollers for tight seals
- Heavy duty side-belt drives ensure square cases
- Adjustable leg supports
- Easy case-size change-over – two crank handles
- Piranha Tape Heads for accurate and consistent sealing
- T-Rail System for quick and easy packaging
- Extended belts to pull the case through the top and bottom flap folders

Model SD-553FTB

The operator simply sets the new box on the T-Rail, folding the bottom minor flaps as the box is set down. The operator fills the box with product and folds down the trailing top minor flap as the box is pushed into the drive belts. The drive belts pull the box through the top and bottom folder system and through the Piranha tape heads where tape is applied to seal the top and bottom of the box. The attached T-Rail makes it easy for the operator to pack boxes.

FOLDING THE BOTTOM



FOLDING THE TOP



READY FOR PACKING



SIDE BELT ADJUSTABLE TOP AND BOTTOM FLAP FOLDING SEALER

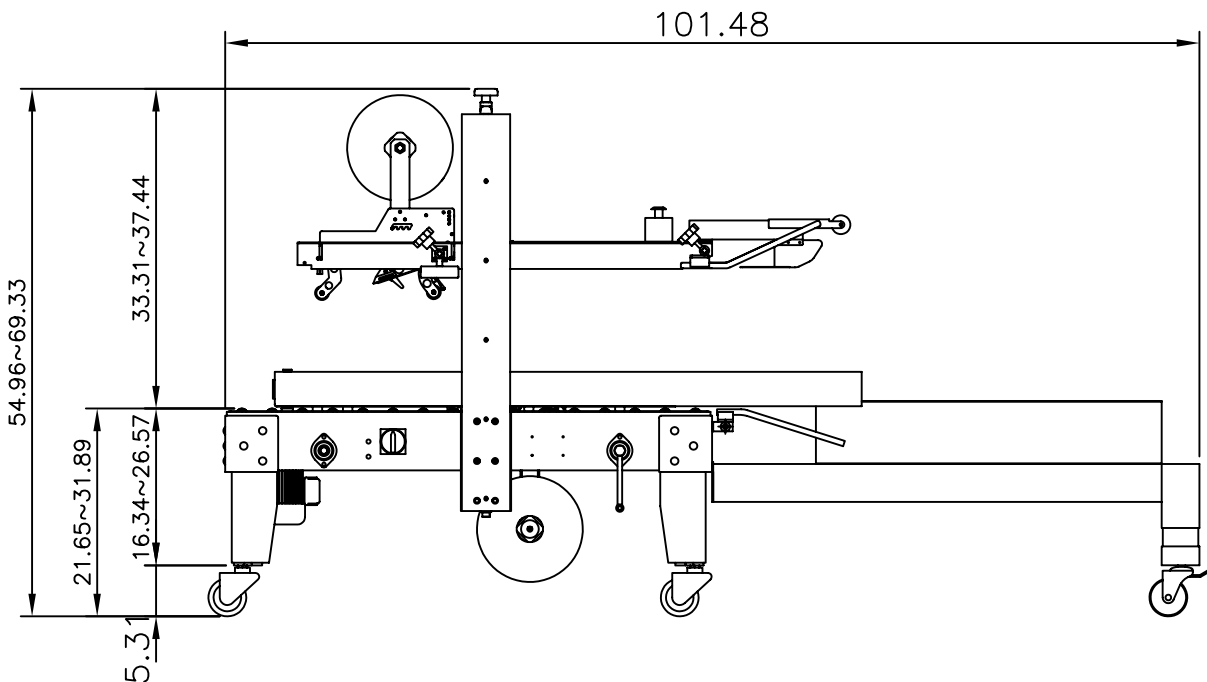
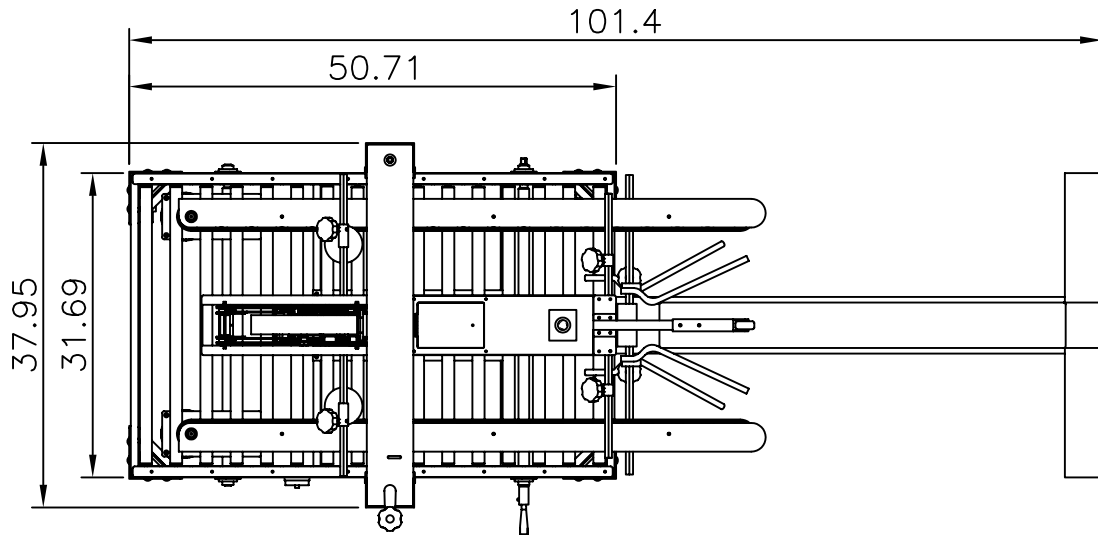

P.O. Box 635 • N7212 FARWELL ROAD • BEAVER DAM, WI 53916
PHONE: 920.885.9299 • TOLL FREE: 877.885.9299 • FAX: 920.885.0288
SALES@ABSEALER.COM • WWW.ABSEALER.COM